

# LOGSET 5F GT

*Favorite forwarder model has been renewed!*

The compact 12-ton Logset 5F GT forwarder is the most sold Logset forwarder model in Finland, the Baltic countries and France. According to our customers the forwarder is world class especially when it comes to felling operations on soft grounds. The updated machine model has a new AGCO diesel engine according to the Stage 5 emission regulations from EU.

Logset 5F GT is a versatile and compact forwarder. It is extremely well adapted for thinning operations, but can also be used for smaller clear felling operations. The large 26,5" tires and the high ground clearance make this machine the right choice for various types of terrain. The forwarder is compact, so turning in tight corners is easy without compromising the ground clearance. The Logset 5F GT is very reliable and does not require a lot of spare parts. Thanks to these features, it has exceptionally low running costs.

High productivity also requires the best possible ergonomics. The cabin has efficient noise insulation and the large windows offer excellent visibility in all directions. The user friendly TOC 2 control system gives a good precision both for crane and transmission. An experienced driver can work fast and efficiently without strain. The automatic cruise control allows the driving speed to be easily adjusted with a potentiometer. The constant driving speed facilitates the operator's work and lowers the fuel consumption. Easy access for service jobs and a big fuel tank minimize the service interruptions.

**LOGSET**

Logset Oy  
Hännisentie 2  
FI-66530 Koivulahti  
FINLAND  
Tel. +358 10 286 3200

**LOGSET**  
SIMPLY BETTER  
[www.logset.com](http://www.logset.com)

SIMPLY BETTER

**LOGSET**

# LOGSET GT Forwarder



5F GT

Forwarder range 08/20 - EN  
We reserve the right to make changes without prior notice.  
All technical specifications are for guidance only.  
The pictures and diagrams do not always show standard versions of the machines.  
Copyright Logset Oy.





# Compact forwarder for difficult terrain

## ENGINE

The updated 5F GT model has a 4-cylinder AGCO Power 49 LFTN diesel engine. The new engine has approximately 20 horse powers more than the previous model with 140 kW instead of 127 kW. The new engine is easier to service. Hydraulic lash adjustment makes the valve clearance adjustment unnecessary, which reduces the time needed for interval services.

## CABIN

The cabin offers first-class comfort and an unobstructed view both when driving and loading. It is spacious and has big storage compartments. The forwarder is easy to maneuver because the wheels are in sight. Add Smooth Ride cabin suspension to improve the operator ergonomics.

## CRANE

A great advantage of the Mesera crane is its boom geometry. The crane is especially designed for forwarders, and makes loading and unloading comfortable and easy. The forwarder is delivered with a Mesera 83 crane as standard. Integrated hoses are an option.

## TOTAL OPERATION AND CONTROL SYSTEM 2 (TOC 2)

The forwarder is equipped with the user-friendly TOC 2 machine control system. Thanks to the control system, the operator saves a great deal of fuel and the driving experience is soft and smooth. The crane control is also fast and accurate.



## FUEL AND HYDRAULIC TANKS

The 188-liter fuel tank allows you to extend your work shift without refueling. The correct dimensioning of the oil tank in each machine model ensures a longer lifespan of the hydraulic components.

## BOGIES

The machine is available with or without balancing on the NAF bogies, depending on your needs.

## TRACTIVE EFFORT

The hydrostatic transmission performs optimally even in difficult terrains. It is powerful, accurate and reliable.

## LOAD BAY

The Logset 5F GT has an adjustable load bay length ranging from 4.15 meters to over 4.80 meters. This forwarder is one of the most versatile Logset machines, as it can be adapted to your individual needs. The machine is also available with a longer back frame, which makes the load bay up to 5 meters long.

# Technical data



MODEL	5F GT
<b>DIMENSIONS</b>	
Own weight from, kg	15 500 (... lbs)
Load capacity, kg	12 000 (26 500 lbs)
Load area length, m	3.6/4.2
<b>ENGINE</b>	
Type	AGCO Power 49 LFTN
Stage	EU Stage V
Power at 1900 rpm, kW	140 (190 hp)
Torque at 1500 rpm, Nm	800 (590 ft lb)
Fuel tank, l	188 (50 US gal)
DEF tank, l	30 (7,9 US gal)
<b>TRANSMISSION</b>	
Type	Hydrostatic mechanical
Tractive effort, kN	169 (37 993 lbf)
Gear box	2 gears
<b>HYDRAULIC SYSTEM</b>	
Pump size, cm <sup>3</sup>	140
Pressure, Mpa	23
Oil tank, l	175 (46 US gal)
<b>CABIN</b>	
Control system: TOC 2 • Battery Voltage: 24V • Safety tested and approved cabin	
<b>WHEELS</b>	
Tyres	710/45-26.5
<b>CRANE OPTIONS</b>	
Crane	Mesera 83
Lifting capacity, kNm	106 (78.180 ft lb)
Reach options, m	7.2/8.5/10 (23/27/32 ft)
Rotator, °	360
<b>OPTIONAL EQUIPMENT</b>	
Smooth Ride cabin suspension • Bulldozer blade • Diesel heater • Crane tilt • Contact your local dealer for more information about other options	

## 5F GT

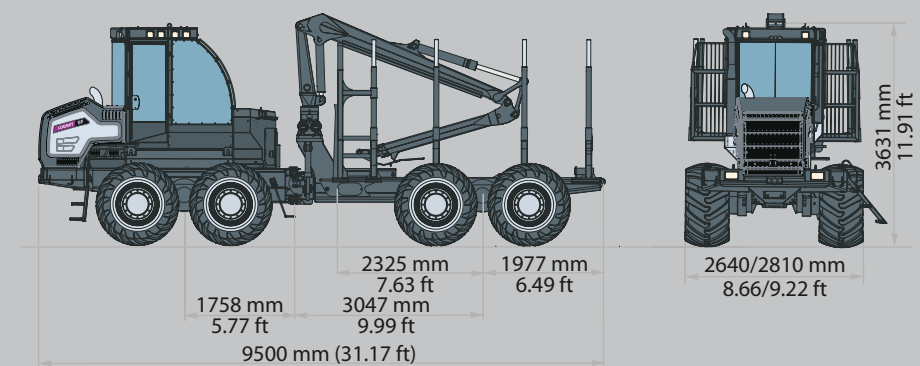

SIMPLY BETTER

**LOGSET**